

HOW TO ATTACH THE WALL METAL FITTINGS OF SP349

- 1. Unpacking :** Confirm that all accessories are included.

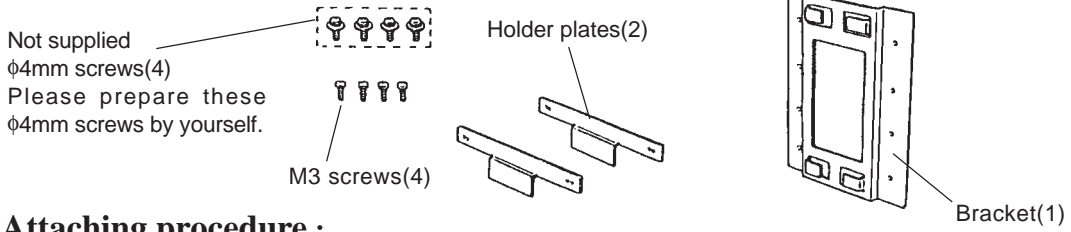

2. Attaching procedure :

Note1) Unplug the power plug from the outlet.

Note2) Select a position on the wall which is not subjected to mechanical shocks or water drops. Also confirm that the wall is sufficiently wide for attaching the bracket.

2-1 How to attach the bracket

- ① If attachment of the bracket on the wall is not possible, first fix a wooden plate whose size is more than 120mm×170mm×5mm.
- ② Apply the bracket and mark the positions of the screw holes.
- ③ Drill screw holes in the marked positions.
- ④ Firmly tighten and fix the bracket to the wall with screws.

Attach and fix the bracket with the four φ4mm screws.

Please prepare screws of sufficient length to secure the bracket.

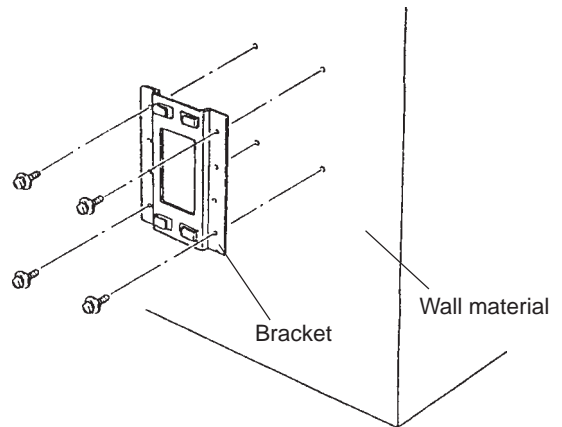

2-2 How to attach the holder plate

- ① Remove the rubber foot.
- ② Firmly tighten the two accessory screws M3 in the direction shown in the figure to attach the two holder plate onto the printer. Tightening torque : 9kg fcm ± 1kg fcm

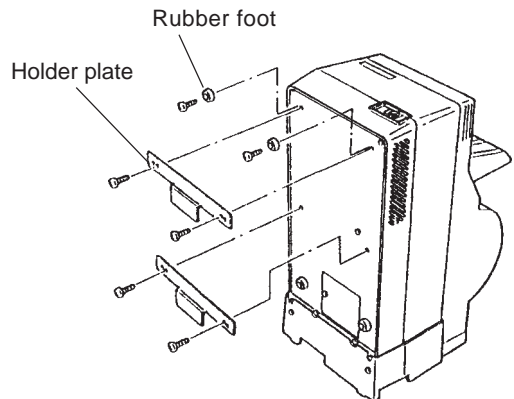

2-3 Setting

Slide the printer main unit downward from the top of the bracket so that the holder plate guides it to a secure position.

